

# Stepper MOTOR

110SH150 High Torque Hybrid

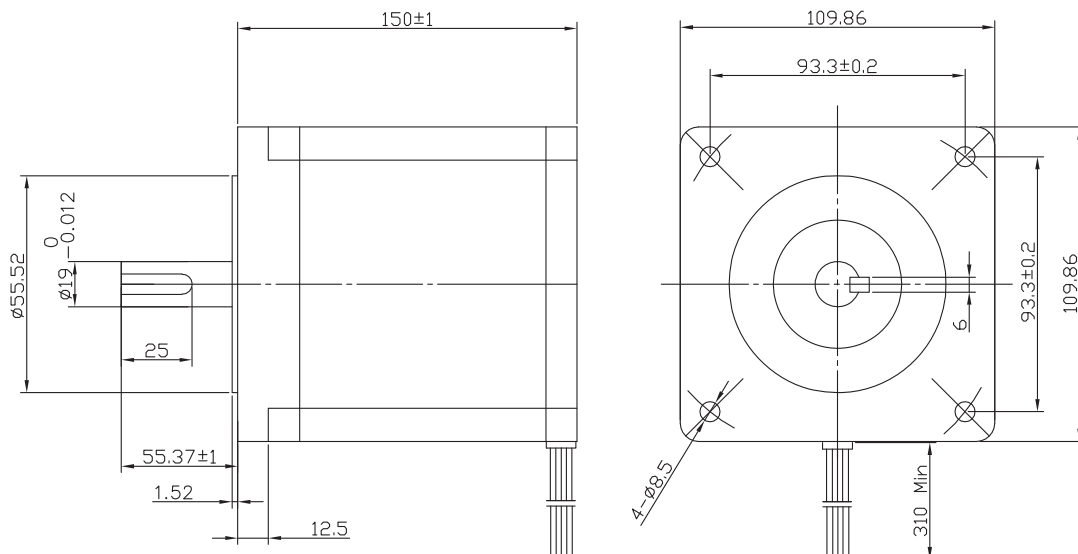

BE version: rear shaft 13mm- 2x M2.5 on diam. 46 mm

## Characteristics

STEP ANGLE  
1,8°

STEP ANGLE ACCURACY  
± 5%

INSULATION CLASS  
B

AMBIENT TEMPERATURE  
-20°C +50°C

TEMP. RISE  
80°C MAX (RATED CURRENT, 2 PHASE ON)

INSULATION RESISTANCE  
100 M OHM MIN. 500 VDC

DIELECTRIC STRENGTH  
820 VAC FOR ONE MINUTE

SHAFT RADIAL PLAY  
0,02 MAX (450 G LOAD)

SHAFT AXIAL PLAY  
0,08 MAX. (450 G LOAD)

MAX RADIAL FORCE  
220 N (20 MM FROM FRONT FLANGE)

MAX AXIAL FORCE  
60 N

## Connection

LEAD N°	COLOR	GAUGE	FUNCTION
1	RED	UL1430 AWG18	PHASE A
2	WHITE	UL1430 AWG18	PHASE A-
3	YELLOW	UL1430 AWG18	PHASE B
4	GREEN	UL1430 AWG18	PHASE B-

## Specification

Model	110SH150-6504A		
1 RATED VOLTAGE	V	5,2	
2 CURRENT/PHASE	A	6,5	
3 RESISTANCE/PHASE	Ω	0,72	
4 INDUCTANCE/PHASE	mH	11,5	
5 HOLDING TORQUE	NM	22	
6 ROTOR INERTIA	G-CM <sup>2</sup>	10900	
7 WEIGHT	KG	8,4	
8 NUMBER OF LEADS	N°	4	

## Speed vs. Torque Characteristics

