

# Stepper MOTOR

42SH38 High Torque Hybrid

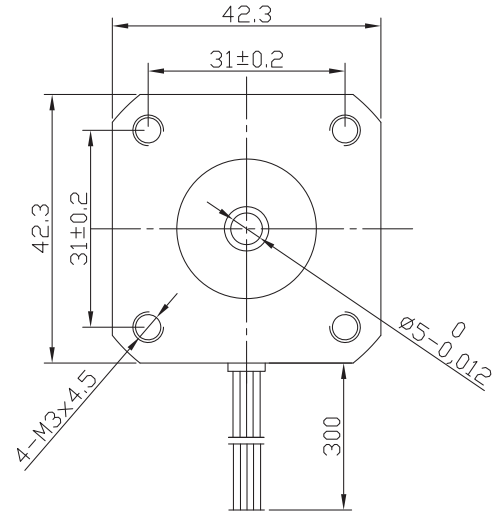
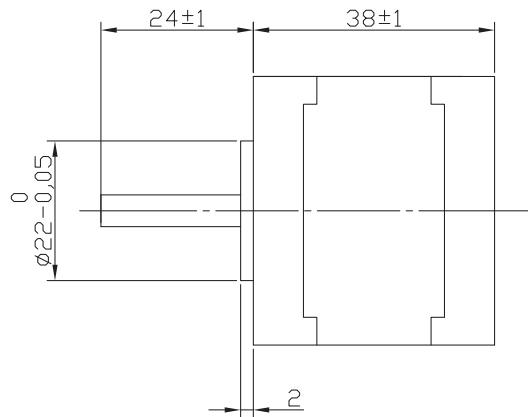

BE version: rear shaft 13mm- 2x M2.5 on diam. 19.05 mm

## Characteristics

STEP ANGLE  
1,8°

STEP ANGLE ACCURACY  
± 5%

INSULATION CLASS  
B

AMBIENT TEMPERATURE  
-20°C +50°C

TEMP. RISE  
80°C MAX (RATED CURRENT, 2 PHASE ON)

INSULATION RESISTANCE  
100 M OHM MIN. 500 VDC

DIELECTRIC STRENGTH  
500 VAC FOR ONE MINUTE

SHAFT RADIAL PLAY  
0,02 MAX (450 G LOAD)

SHAFT AXIAL PLAY  
0,08 MAX. (450 G LOAD)

MAX RADIAL FORCE  
28 N (20 MM FROM FRONT FLANGE)

MAX AXIAL FORCE  
10 N

## Connection

| LEAD N°               | COLOR  | GAUGE        | FUNCTION    |
|-----------------------|--------|--------------|-------------|
| 1                     | BLACK  | UL1430 AWG26 | PHASE A     |
| 2                     | GREEN  | UL1430 AWG26 | PHASE A-    |
| 3                     | RED    | UL1430 AWG26 | PHASE B     |
| 4                     | BLUE   | UL1430 AWG26 | PHASE B-    |
| <b>UNIPOLAR MOTOR</b> |        |              |             |
| 5                     | YELLOW | UL1430 AWG26 | COM PHASE A |
| 6                     | WHITE  | UL1430 AWG26 | COM PHASE B |

## Specification

| Model |                  | 42SH38-1A         | 42SH38-2A | 42SH38-3A | 42SH38-4A |      |
|-------|------------------|-------------------|-----------|-----------|-----------|------|
| 1     | RATED VOLTAGE    | V                 | 4         | 6         | 12        | 2,8  |
| 2     | CURRENT/PHASE    | A                 | 1,2       | 0,8       | 0,4       | 1,68 |
| 3     | RESISTANCE/PHASE | Ω                 | 3,3       | 7,5       | 30        | 1,65 |
| 4     | INDUCTANCE/PHASE | mH                | 3,4       | 6,7       | 30        | 3,2  |
| 5     | HOLDING TORQUE   | NM                | 0,259     | 0,259     | 0,259     | 0,36 |
| 6     | ROTOR INERTIA    | G-CM <sup>2</sup> | 54        | 54        | 54        | 54   |
| 7     | WEIGHT           | KG                | 0,28      | 0,28      | 0,28      | 0,28 |
| 8     | NUMBER OF LEADS  | N°                | 6         | 6         | 6         | 4    |

## Speed vs. Torque Characteristics

