

Stepper MOTOR

86SH65 High Torque Hybrid

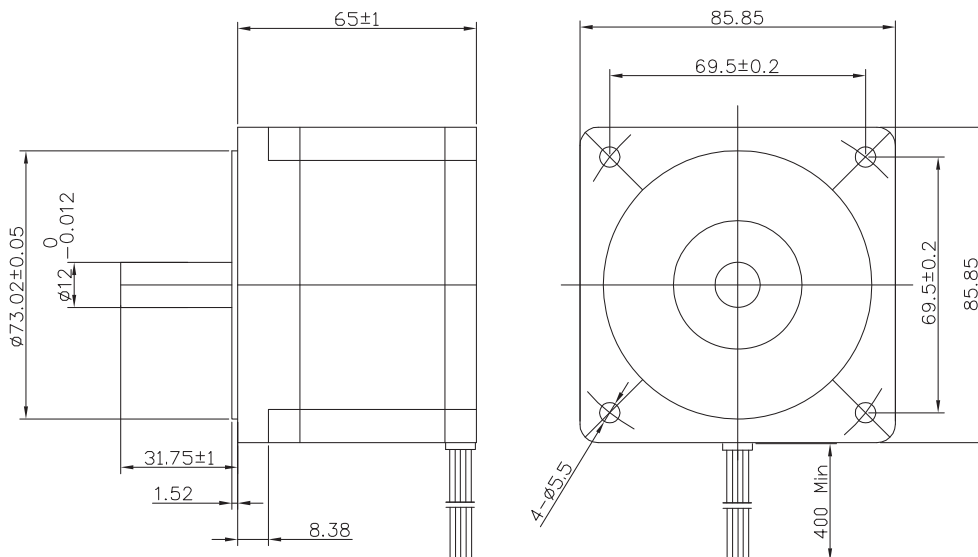
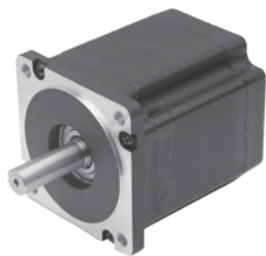

BE version: rear shaft 13mm- 2x M2.5 on diam. 46 mm

Characteristics

STEP ANGLE
1,8°

STEP ANGLE ACCURACY
± 5%

INSULATION CLASS
B

AMBIENT TEMPERATURE
-20°C +50°C

TEMP. RISE
80°C MAX (RATED CURRENT, 2 PHASE ON)

INSULATION RESISTANCE
100 M OHM MIN. 500 VDC

DIELECTRIC STRENGTH
820 VAC FOR ONE MINUTE

SHAFT RADIAL PLAY
0,02 MAX (450 G LOAD)

SHAFT AXIAL PLAY
0,08 MAX. (450 G LOAD)

MAX RADIAL FORCE
220 N (20 MM FROM FRONT FLANGE)

MAX AXIAL FORCE
60 N

Specification

Model		86SH65-4208A		
		UNIPOLAR	PARALLEL	SERIES
1	RATED VOLTAGE V	2,39	1,65	3,42
2	CURRENT/PHASE A	4,2	5,9	3
3	RESISTANCE/PHASE Ω	0,57	0,28	1,14
4	INDUCTANCE/PHASE MH	1,7	1,7	6,8
5	HOLDING TORQUE NM	2,6	3,4	3,4
6	ROTOR INERTIA G-CM ²		1000	
7	WEIGHT KG		1,7	
8	NUMBER OF LEADS N°		8	
9	LENGTH MM		65	

Speed vs. Torque Characteristics

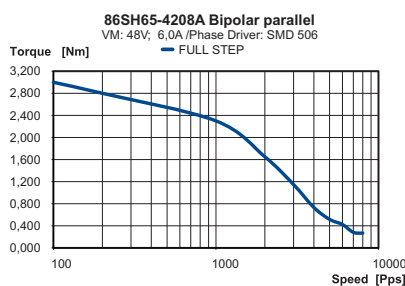

Connection

LEAD N°	COLOR	GAUGE	FUNCTION
1	RED	UL1430 AWG20	PHASE A
2	YELLOW	UL1430 AWG20	PHASE A-
3	BLUE	UL1430 AWG20	PHASE C-
4	BLACK	UL1430 AWG20	PHASE C
5	WHITE	UL1430 AWG20	PHASE B
6	ORANGE	UL1430 AWG20	PHASE B-
7	BROWN	UL1430 AWG20	PHASE D-
8	GREEN	UL1430 AWG20	PHASE D

